

The **BLD02** is a **non-invasive, optical sensor** with remote electronics (probe and PCB) developed to detect smallest amounts of blood in a clear fluid from the outside through transparent plastic tubing.

The sensitivity is defined by international standard IEC 60602-2-16: The sensor detects 0.35 ml / min of blood at a hematocrit level of 0.32 at the maximum specified flow rate.

The BLD02 meets highest demands on patient safety and reliability: The software has been designed strictly according to the requirements of the international standard IEC 62304:2006, safety class C.

## Technical Data

<b>Blood Leak Detector Type BLD02</b>	
<b>Measuring method</b>	Optical transmission measurement
<b>Specification</b>	<b>BLD02/50</b>
<b>Order number</b>	700 01 0255
<b>Blood sensitivity</b>	0.35 ml/min at a dialysis fluid flow rate of 800 ml/min, haematocrit level of 32 % (IEC 60601-2-16:2008)
<b>Measuring cycle</b>	≥13 μs
<b>Response time; Holding time</b>	≤100 ms; On request: Delay for blood alarm
<b>Materials</b>	Housing: ABS and PMMA; Potting: PUR
<b>Versions / Designs</b>	The sensor version depends on the tube diameter. Please provide us with a sample of the tube (approx. 30 cm), so that we can select the optimal design.
<b>Measuring channel</b>	Width: 5.0 mm; Height: 5.8 mm
<b>Mounting</b>	Clamp-on sensor, free hanging on tubing, Ears with fixation screw holes (Ø=3.25 mm)
<b>Operating temperature</b>	+5 °C to +50 °C
<b>Storage temperature</b>	-20 °C to +70 °C
<b>Protection</b>	IP65

<b>Operating voltage</b>	3.3 ... 5.5 VDC, ⚠ <b>NOTE:</b> No overvoltage protection implemented.	
<b>Current consumption</b>	≤ 30 mA with open current output	
<b>Requirements for tube</b>	<b>Parameter</b>	<b>Property</b>
	Outer diameter	5.5 ... 7.0 mm
	Material	Plastics, e.g. PVC, PE, silicone, PUR, other materials on request
	Special features	Tube must be optically transparent within the spectral range of about 420 nm
	Elasticity	Tube must be able to adjust flexibly
	Tube is inserted into sensor without any coupling fluid	
<b>Requirements for liquid</b>	Optically transparent liquids	
<b>Directives / Standards</b>	<p>The sensors were developed to be tested with respect to the following standards:</p> <ul style="list-style-type: none"> <li>• Safety requirements: IEC 60601-2-16:2008</li> <li>• EMC: IEC 60601-1-2:2007</li> <li>• Software is developed acc. to IEC 62304:2006. The embedded software is classified as "C"</li> </ul>	
<b>Scope of delivery</b>	Blood leak detector type BLD02 sensor head with connection cable; printed circuit board (PCB) and Technical Data Sheet	

**Electrical Connection – Interfaces / Connectors on PCB**

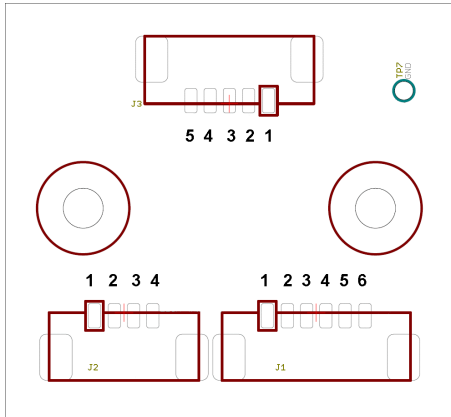

**⚠ ATTENTION:** The board needs to be protected against direct contact with external electronic potentials

J1 – Digital Interface						
<b>Connector</b>	3.3 V LVCMOS, Board connector header; 6-pin; 1.25 mm Molex: 53261-0671					
<b>Assignment</b>	<b>Pin</b>	<b>Connection</b>				
	1	Operating voltage				
	2	GND				
	3	Output blood				
	4	Input self-test (high active)				
	5	Output plausibility check				
	6	Input calibration (high active)				
<b>Logical specification</b>	<b>Condition</b>	<b>Blood</b>	<b>Plausibility</b>			
<i>Signal at output</i>	Blood	high	high			
	Clear liquid	low	high			
	Plausibility error	low	low			
	Internal error	high/low	low			
<b>Logical level</b>	<b>Parameter</b>	<b>Condition</b>	<b>Min</b>	<b>Typ</b>	<b>Max</b>	<b>Unit</b>
<i>Signal at output</i>	Output High Voltage	$I_{OH} = -3 \text{ mA}$ , Port I/O push-pull	2.225	---	---	V
		$I_{OH} = -10 \text{ }\mu\text{A}$ , Port I/O push-pull	2.825	---	---	V
		$I_{OH} = -10 \text{ mA}$ , Port I/O push-pull	---	2.125	---	V
	Output Low Voltage	$I_{OL} = 8.5 \text{ mA}$	---	---	0.6	V
		$I_{OL} = 10 \text{ }\mu\text{A}$	---	---	0.1	V
$I_{OL} = 25 \text{ mA}$		---	1	---	V	
Input High Voltage			2.0	---	---	V
Input Low Voltage			---	---	0.8	V

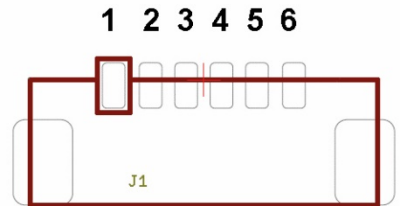

**J2 – Serial Interface\***

<b>Connector</b>	Board connector header; 4-pin; 1.25 mm Molex: 53261-0471	
<b>Assignment</b>	<b>Pin</b>	<b>Connection</b>
	1	Operating voltage
	2	GND
	3	Tx
	4	Rx

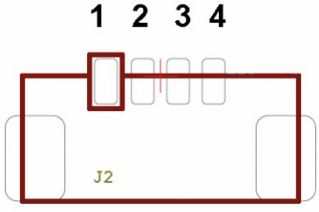

<b>Serial interface</b>	<b>Parameter</b>	<b>Value</b>
	Bits per second	115200
	Data bits	8
	Parity	none
	Stop bits	1
	Flow control	none

\* Activation depends on software version.

**J3 – Connection to Sensor Head**

<b>Connector</b>	Board connector header; 5-pin; 1.25 mm Molex: 53261-0571	
<b>Assignment</b>	<b>Pin</b>	<b>Connection</b>
	1	GND
	2	VDD
	3	Out
	4	LED VDD
	5	LED GND

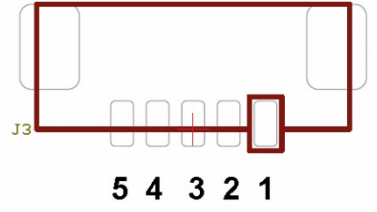

Technical Drawings

Sensor head with light source

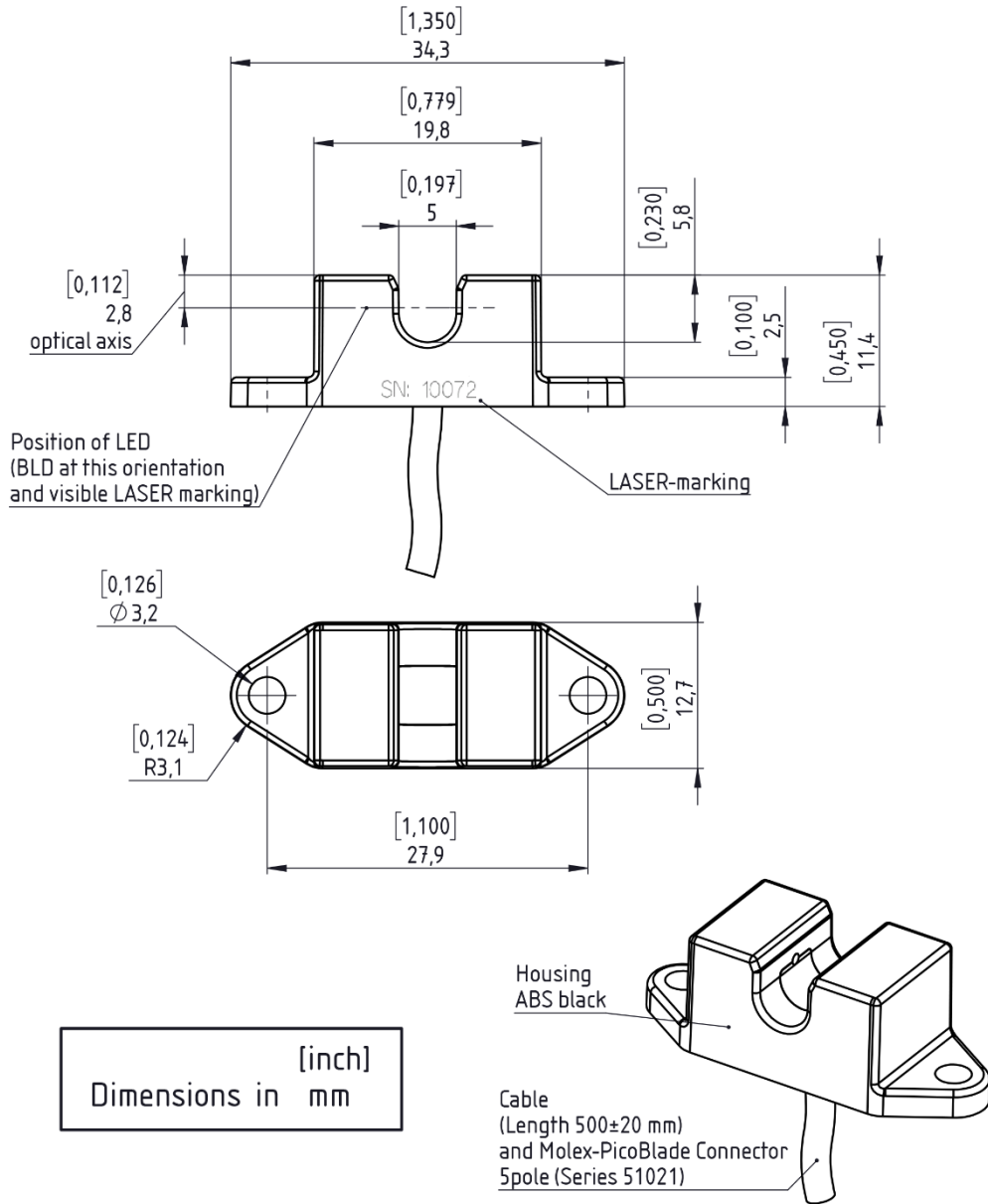

**Remote electronics: printed circuit board (PCB)**

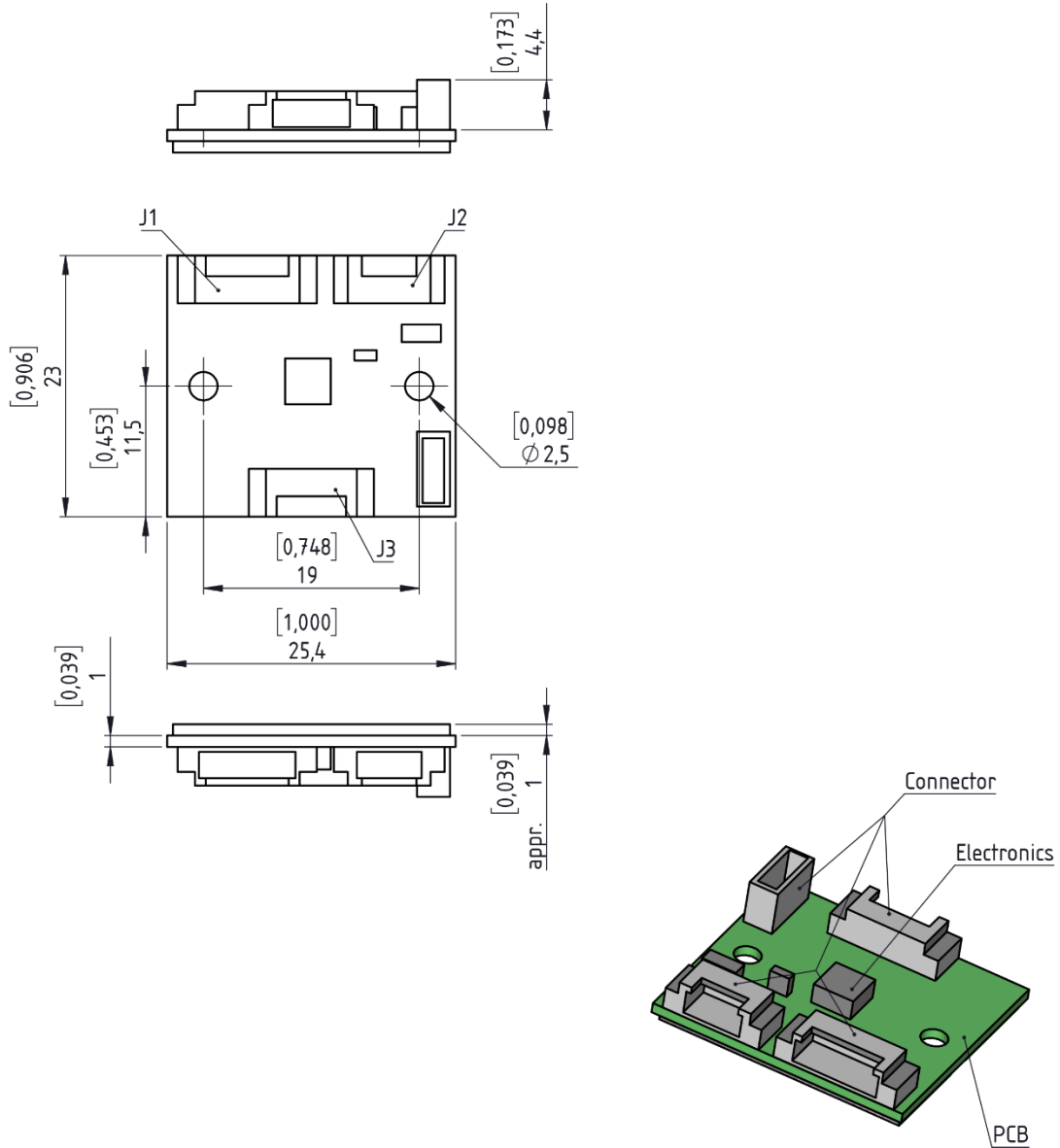

Drawings are not to scale. Information is subject to change without notice!

**HEADQUARTERS GERMANY**

SONOTEC GmbH  
 Nauendorfer Str. 2  
 06112 Halle (Saale)  
 Germany

Tel.: +49 (0)345 / 133 17- 0  
 sales\_eu@sonotec.de  
 www.sonotec.eu

**AMERICAS**

SONOTEC US Inc.  
 190 Blydenburgh Rd  
 Suite 8, 2<sup>nd</sup> Floor  
 Islandia, New York 11749, USA

Phone: +1 631 / 415 4758  
 sales@sonotecusa.com  
 www.sonotecusa.com