



Operating Manual

BS40

Broadband structure-borne sound sensor for the SONAPHONE handheld unit

Translation of the German Original

Revision: 1.2 | 2024-03-01

Content

1	Introduction	3
1.1	Notes on this documentation.....	3
1.2	Representations in this documentation.....	3
1.3	Identification of warning instructions	4
2	Safety instructions	5
2.1	Introduction.....	5
2.2	Basic hazards	5
2.3	Personnel and qualifications.....	6
2.4	Use of the product.....	6
2.5	Modifications and alterations	7
3	Description of the sensor	8
3.1	Intended use.....	8
3.2	Prohibited use.....	8
3.3	Sensor construction.....	9
3.4	Sensor identification	9
3.5	Accessories.....	10
4	Operation of the sensor	12
4.1	Requirements on the point of measurement.....	12
4.2	Preparing the point of measurement.....	12
4.3	Coupling the sensor.....	13
4.3.1	Magnetic coupling for temporary measurements.....	13
4.3.2	Screwed coupling for semi-stationary measurements.....	16
5	Cleaning and maintenance	17
5.1	Cleaning	17
5.2	Maintenance	17
6	Technical data	18
7	Disposal	20
8	Warranty	21
9	Manufacturer information	22

1 Introduction

This section is intended to explain function, structure and representations of this documentation to simplify handling of this documentation.

1.1 Notes on this documentation

Purpose

This documentation constitutes an integral part of the product and contains important advice on safe operation as well as all information on intended and efficient use. Thus, any person using the product must have read and understood this documentation.

Accessibility

The staff working with this product must have constant access to this documentation to prevent handling errors and guarantee trouble-free operation.

Up-to-dateness

Every effort has been made to ensure that the information contained in this documentation is complete and correct at the time of release. This documentation describes all units and functions known at the current point of time.

1.2 Representations in this documentation

Illustrations

Illustrations used in this documentation do not always contain all details or special cases. They only represent the relevant information.

Tips

Tips are marked as follows:

ⓘ Tips describe specific information or particular features that might not be evident, even for experienced users. The neglect of a tip poses no direct safety risk. However, it can lead to workflow disruptions.

General icons

The following general icons are used for visual emphasis:

Icon	Function
🔗	Indicates a link to external contents.

1.3 Identification of warning instructions

Classes of danger, signal words and colors

This documentation contains warnings regarding hazards of different classifications. These classes are characterized by signal words and colors. They include the following:

WARNING

Warns of possible immediate danger, which, if ignored, may lead to lasting damage to health and/or property – including financial losses due to operational impairment.

CAUTION

Warns of dangers, which, if ignored, may lead to injury or damage to property – including damage to property due to operational interruptions.

ATTENTION

Warns of dangers, which, if ignored, may lead to damage to property – including damage to property due to operational interruptions.

2 Safety instructions

This section contains safety information relating to the protection of persons as well as safe and fault-free operation. All user groups of the product must be aware of and follow these safety provisions.

2.1 Introduction

Reliable and safe operation of the product depends on the careful handling and execution of operational and setting tasks.

Ignoring these safety instructions and warning information may lead to serious injury with lasting health consequences for personnel as well as damage or destruction of product components.

During handling of the product, please observe all safety instructions and warning information in all parts of this user documentation as well as the related codes of practice. Ensure that all those working with the product are also aware of these instructions.

Generally applicable safety regulations (such as accident prevention and environmental protection regulations, etc.) must also be observed.

2.2 Basic hazards

Definition

Basic hazards are residual risks that remain even with safety-conscious intended use.

State of the art

The product meets the current state of the art and applicable safety rules. All components of the product are tested thoroughly before they leave the factory and are delivered in a condition for safe operation.

▲ WARNING

Danger of injury!

Improper use of the product may lead to injuries.

- Do not open the product.
 - Protect the product against extreme heat (excessive sunlight, immediate vicinity of open fire or heating devices) during operation and storage.
 - Avoid strong impacts that could damage the device and/or its components.
-

2.3 Personnel and qualifications

Basic requirements

The product must only be used by operators that have completely read and understood the safety instructions and all documents of the user documentation.

Personnel undergoing training or instructions or persons taking part in general vocational training programs may only operate the device under the continuous supervision of operating or technical personnel.

Responsibility of the operating company

Regarding the personnel authorized and/or trained by the operating company, the operating company carries the following responsibilities:

- The necessary training and instruction of personnel must be guaranteed.
- All personnel's competences and responsibilities must be clearly stated and documented.
- All user information on the product (operating manual, user documentation etc.) must be kept in the immediate vicinity of the product and must be accessible at all times.

2.4 Use of the product

Measures for personal safety

Improper use of the product may lead to injuries of operating personnel.

- Always make sure that both hands are free for self-protection, if necessary.
- Always make sure to keep your hands, the product and/or connected equipment within your field of vision.

Measures for protection of the product and/or equipment

Improper use of the product may lead to product damage. Damaged components may affect or distort the measurement result quality.

- During use, charging and storage, protect the device against extreme, unusual heat (excessive sunlight, storage in heated cars or immediate vicinity of open fire or heating devices). It is critical to stay within the temperature ranges given in the technical specification.
- Do not use the product and its accessories if they display functional errors and/or visible damage.
- Only connect the product to approved equipment received from SONOTEC GmbH or its sales partners.
- The product adheres to the protection class given in the technical specification and is not protected against water. Do not submerge the product in liquids. Protect the product against moisture penetration.
- Handle the product with care and protect it against major shocks.
- When using the product, always make sure that cables cannot get stuck and/or caught in moving parts.
- Do not use the product within strong electromagnetic fields.

2.5 Modifications and alterations

No modifications on the product and/or accessories

The product and/or its accessories must not be opened or disassembled. The product does not contain any components to be cleaned, maintained or repaired by operators.

Unauthorized modifications of the product and/or its accessories are prohibited and lead to exclusion of liability by the manufacturer for resulting damage and consequences.

Spare parts and accessories

Spare parts and accessories must comply with the technical requirements specified by SONOTEC GmbH and its suppliers. Whenever original parts are used, compliance is given.

No alterations to the software

Do not alter the supplied software or commission software alterations to third parties. The software may not be disassembled, decrypted or decompiled in full or in part.

3 Description of the sensor

This section describes use, function, structure and accessories of the sensor.

3.1 Intended use

The Broadband structure-borne sound sensor BS40 is used in combination with the SONAPHONE digital ultrasonic testing device. Applications of the sensor include condition monitoring of machines, systems and processes with detectable structure-borne sound in the ultrasonic range.

Variance of the sound signals indicate a change in condition and/or process of the test object. The detection of this variation is the basis of condition monitoring in preventive maintenance.

The Broadband structure-borne sound sensor BS40 is preferably used for magnetic machine surfaces or points of measurement.

The coupling mode at the point of measurement depends on the test type. For recurring measurements with measurement data recording, the sensor may be attached by a magnetic foot or a general-purpose magnet. For continuous monitoring or fixed attachment, the sensor may be screwed in with a threaded pin.

3.2 Prohibited use

Any use not approved by SONOTEC GmbH is prohibited and may lead to injury or damage to property.

SONOTEC GmbH accepts no liability for damage caused by prohibited use of the product.

Prohibited are in particular:

- Use of equipment and/or accessories with visible damage
- Use in wet rooms
- Use in potentially explosive environments
- Use in environmental conditions that do not adhere to the stipulated requirements
- Unauthorized modifications of the equipment, the software and/or accessories
- Use of unauthorized spare parts and/or unauthorized accessories

3.3 Sensor construction

Sensor elements



Figure 1: Sensor elements of the BS40

No.	Component
1	Ultrasonic transducer with UNF ¼" 28 threaded pin
2	Status LED <ul style="list-style-type: none">• green light: sensor is activated• red light: sensor is in boot mode• orange light: sensor is in service mode <div style="border: 1px solid black; padding: 5px;"><p>ⓘ Boot mode is required for sensor firmware updates. (see Updating sensor firmware with the SONAPHONE Hardware Manager app)</p></div>
3	Sensor cable socket <ul style="list-style-type: none">• Type: LEMO 0B (4-pin)• with marked plug-in position

3.4 Sensor identification

Identification plate

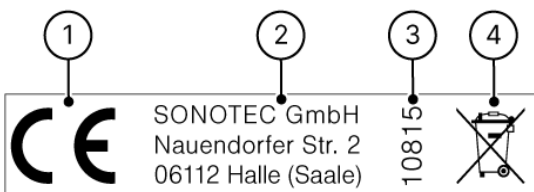

Figure 2: Identification plate with its components

No.	Identification
1	CE marking
2	Manufacturer's address
3	Serial number
4	Disposal symbol (see "7 Disposal", page 20)

3.5 Accessories

Intensity and behavior of ultrasonic signals depend on factors such as the process during which they are generated. Measurement value recordings with high signal quality are necessary for valid conclusions on system conditions. Signal quality also depends on a number of factors.

To record high-quality signals for processing in the sensor, equipment for differing applications is available.

Flat surface magnetic base



Including protective plate (without picture)

Application	<ul style="list-style-type: none"> • Magnetic sensor coupling on even coupling surfaces for recurring temporary tests • Including UNF ¼" 28 internal thread for screwing on the sensor
Article number	300 01 0102

Multi-purpose magnetic base



Including protective plate (without picture)

Application	<ul style="list-style-type: none"> • Magnetic sensor coupling on curved surfaces for temporary tests • Including UNF ¼" 28 internal thread for screwing on the sensor
Article number	300 01 0103

Mounting pad



Application

- Fitting a designated coupling position for magnetic or screwed sensor coupling for recurring temporary or semi-stationary tests
- Including UNF ¼" 28 internal thread for screwing in the sensor

Article number

300 01 0104

4 Operation of the sensor

This section contains descriptions and instructions for operating the sensor and using it in combination with the SONAPHONE handheld unit.

▲ CAUTION

Risk of crushing by flat surface magnet or multi-purpose magnet!

The magnets exhibit a very strong force. This may cause crushing injuries on the hands during sensor coupling and uncoupling.

- Ensure that your fingers are never positioned between the magnets and the point of measurement.
- Always transport the sensor including magnets with mounted protective plate. The protective plate must only be removed for measurements.

4.1 Requirements on the point of measurement

A point of measurement suited for ultrasonic measurement has to satisfy the following requirements:

- The surface must be level, without dust and grease and free of scratches.
- The point of measurement should not be covered by paint layers.

For satisfaction of these requirements and high reproducibility of the measurement results, we recommend to mark and prepare the point of measurement.

① Attaching mounting pads (article number: 300 01 0104) allows for consistently comparable coupling conditions.

4.2 Preparing the point of measurement

For correct and reproducible measurement results during recurring measurements, the point of measurement may be prepared as follows depending on the application:

1. Ensure that the surface is clean and free of scratches.
2. If possible, remove the paint layer from the surface.
3. Depending on the application:
Drill a UNF 1/4" 28 threaded hole (depth: 6 mm) or glue a mounting pad.

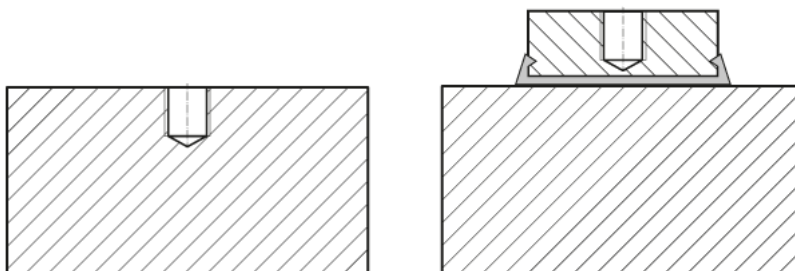

4.3 Coupling the sensor

Correct and reproducible measurement results depend on:

- selection of an appropriate point of measurement,
- selection of appropriate equipment,
- correct alignment and positioning of the sensor depending on the used equipment as well as
- consistent contact pressure of the sensor during measurement value recording.

This section contains descriptions and instructions on coupling the sensor with the corresponding equipment.

ⓘ The frequency characteristic varies depending on the used equipment and/or the coupling mode. Always use the same equipment and/or coupling mode for recurring comparison measurements.

4.3.1 Magnetic coupling for temporary measurements

Coupling methods

For temporary measurements, the sensor may be coupled magnetically with the point of measurement. Depending on the local conditions and the particular application, one of the following coupling methods may be used:

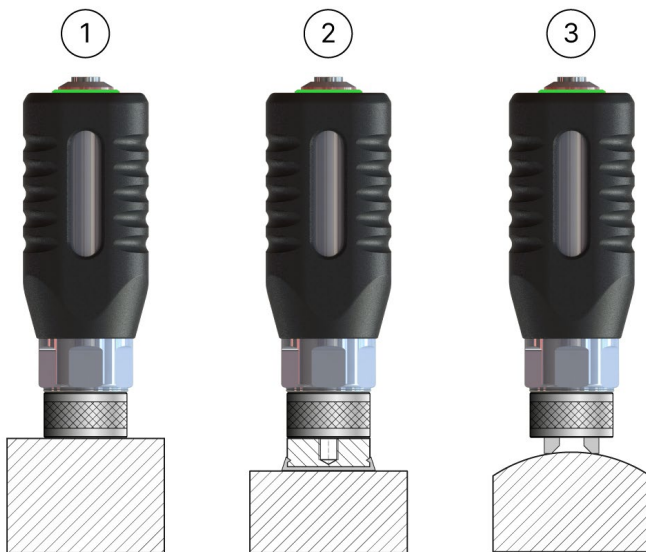

No.	Coupling method
1	Flat surface magnetic base for even coupling surfaces
2	Flat surface magnetic base on glued mounting pad
3	Multi-purpose magnetic base for curved surfaces

Coupling

▲ CAUTION

Risk of crushing by flat surface magnet or multi-purpose magnet!

The magnets exhibit a very strong force. This may cause crushing injuries on the hands during sensor coupling.

- In the first step, always position the sensor inclined and with care on the point of measurement.

1. Screw the required magnet on the sensor and hand-tighten.
2. Push the protective plate (without picture) sideways to remove it from the magnet.
▲ Keep the protective plate for storage and transportation.
3. Carefully position the sensor on the point of measurement by placing the edge of the magnet.



4. Carefully tilt the sensor on the point of measurement until the magnet rests on the point of measurement with its complete surface.

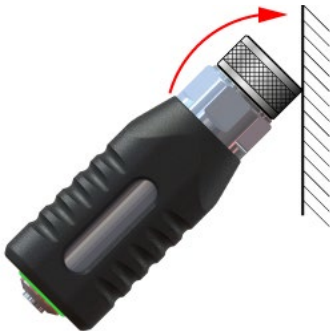

Uncoupling

▲ CAUTION

Risk of crushing by flat surface magnet or multi-purpose magnet!

The magnets exhibit a very strong force. This may cause crushing injuries on the hands during sensor uncoupling.

- Always tilt the sensor at an inclined angle and with care before removing it from the measuring point.
-

1. Carefully tilt the sensor from the point of measurement.

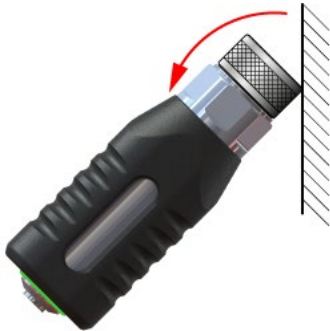

2. Carefully pull the sensor from the point of measurement.



3. Carefully push the protective plate (without picture) sideways on the magnet.

4.3.2 Screwed coupling for semi-stationary measurements

Coupling methods

For semi-stationary measurements, the sensor may be screwed into a prepared point of measurement. Depending on the local conditions and the particular application, one of the following coupling methods may be used:

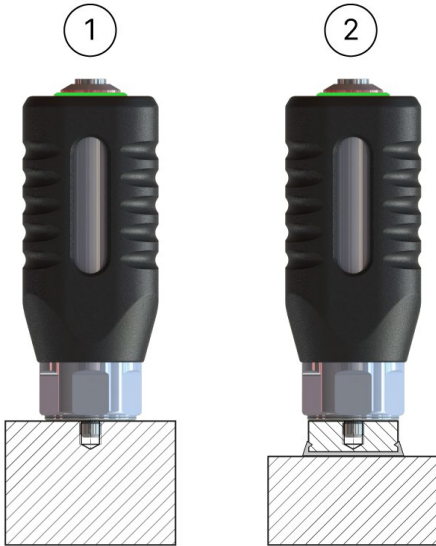

No.	Coupling method
1	Direct screw coupling with the point of measurement
2	Screw coupling with the glued mounting pad

ⓘ The sensor must always be tightened with a defined tightening torque (preferably 2 Nm).

5 Cleaning and maintenance

5.1 Cleaning

Guidelines

Do not open the product! The product contains no parts to be cleaned by the operator.

Suitable cleaning products

Only clean the product on the outside with soft, lint-free cloth.

ATTENTION

Check the compatibility of used cleaning agents!

The compatibility of all cleaning agents with used materials and colors must be confirmed and approved by SONOTEC GmbH or the respective supplier.

Unsuitable cleaning agents

Do not clean the product with:

- scratchy, aggressive, solvent-containing or benzine-containing cleaning agents,
- pressured air, high-pressure cleaner or other kinds of cleaning machine.

After cleaning

After cleaning the device, make sure that:

- cables, connectors and fittings are free of cleaning agents and
- cables, wires, connectors and electrical components are dry.

5.2 Maintenance

Guidelines

Do not open the device! The device contains no parts to be maintained or repaired by the operator.

6 Technical data

General data	
Article number	200 01 0343
Dimensions (L × W × H)	see technical drawing
Weight	210 g (without accessories)
Electrical connection	LEMO 0B (4-pole)
Standards and guidelines	<ul style="list-style-type: none"> • EMC Directive 2014/30/EU • WEEE Directive 2012/19/EU • RoHS Directive 2011/65/EU
Acoustic data	
Frequency range	150 Hz ... 100 kHz
Materials	
Housing material	Stainless steel, rubber (NBR)
Ambient conditions	
Operating temperature	-10 ... +65 °C
Storage temperature	-20 ... +65 °C (up to 40 °C at 90 % humidity)
Protection type	IP50
Order details	
Scope of delivery	<ul style="list-style-type: none"> • Broadband structure-borne sound sensor BS40 • Calibration certificate

Technical drawing

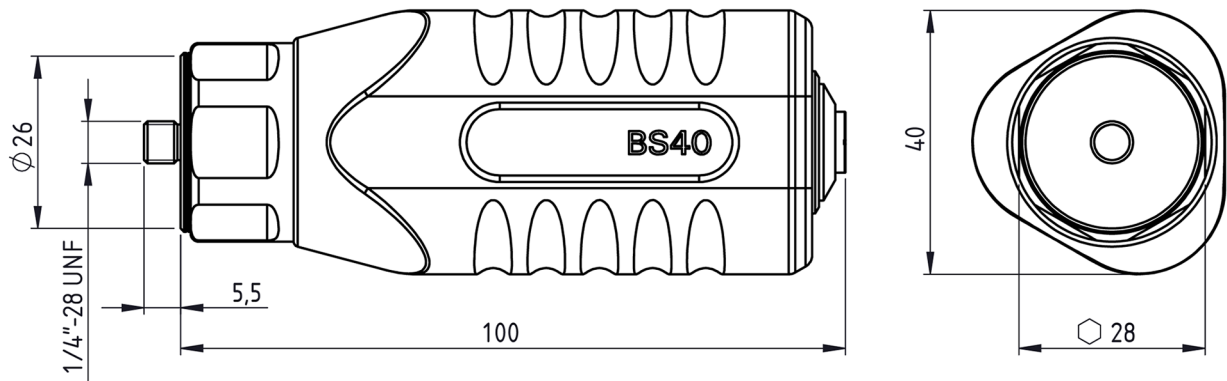

7 Disposal

Recycling and taking back of used equipment

Electrical and electronic devices may pose a risk to health and the environment if disposed of incorrectly. They cannot therefore be disposed of as domestic waste according to WEEE Directive 2012/19/EU (Waste Electrical and Electronic Equipment Directive). Instead they must be taken to designated collecting points or returned to the manufacturer.

The following symbol indicates the legal duty to dispose of electronic devices as stipulated.



They must undergo specified recycling processes (e. g., with respect to batteries or circuit boards) which enable safe, environmentally compatible re-use or separate disposal of different device elements.

The return of used devices is regulated differently in different places. Find out from your local council about the return conditions for commercially used electronic devices.

The device contains no toxic substances requiring separate identification for disposal such as mercury (Hg), cadmium (Cd), lead (Pb) or chrome 6 (e. g., in plated parts or circuit boards).

For accessories (e.g. sensors, probes), special instructions may apply. Follow the instructions in the corresponding user documentation.

8 Warranty

Condition at delivery

All products and accessories have been tested thoroughly before they leave the factory, are state-of-the-art products at the time of delivery and adhere to all applicable safety regulations.

Warranty

During the warranty period, SONOTEC GmbH will eliminate all deficiencies caused by material or manufacturing faults free of charge. SONOTEC GmbH will at its own discretion offer warranty by reparation or replacement of faulty products.

Exceptions

Internal accumulators as well as damage caused by unintended use, by wear or by manipulation of the product are exempt from warranty. The warranty also does not cover those faults that affect value or usability of the product to a negligible amount.

Responsibility of the user/operator

It lies within the responsibility of the users to ensure that the product has been installed and set-up properly and is used in a manner that does not impair safe operation.

Operating errors

Operating errors can never be completely ruled out by the manufacturer. SONOTEC GmbH is in no way liable for any direct or indirect damage caused by operating errors (e.g. damage on software and/or hardware, damage by downtime, damage by malfunction as well as damage or loss of measurement and test data).

Quality of captured data

The determination of valid test results, their interpretation and the actions derived therefrom are exclusively subject to the personal responsibility of the users. SONOTEC GmbH does not guarantee the correctness of determined test values and/or test results. SONOTEC GmbH does not assume liability for any faults or damages that might occur due to further use of determined test and measurement values.

9 Manufacturer information

Copyright

© SONOTEC GmbH

All rights reserved.

All contents of this document are property of SONOTEC GmbH and are protected by copyright. Duplication, modification and/or distribution in any form, particularly for reprint, for photographic, mechanical or electronic reproduction or in the form of saving in data processing systems or data networks is forbidden without written approval by SONOTEC GmbH.

Certifications and registrations

- Quality management according to ISO 9001:2015
(Certificate Registration No.: 091006014)
- Registration according to ElektroG at the 'stiftung elektro-altgeräte register' (ear):
WEEE Reg. No. DE 22125904

Contact

Manufacturer

SONOTEC GmbH
Nauendorfer Str. 2
06112 Halle (Saale), Germany
Phone: +49 345 13317-0
mySONAPHONE@sonotec.de
www.sonotec.eu

USA

SONOTEC US Inc.
10 Newton Pl., Ste. 100
Hauppauge, NY 11788
USA
Phone: +1 631 4154758
sales@sonotecusa.com
www.sonotecusa.com